

Telequip Transact 2+ Quick Reference Card

The following picture shows the Transact 2+ Coin Dispenser (dual-voltage model) and its parts.

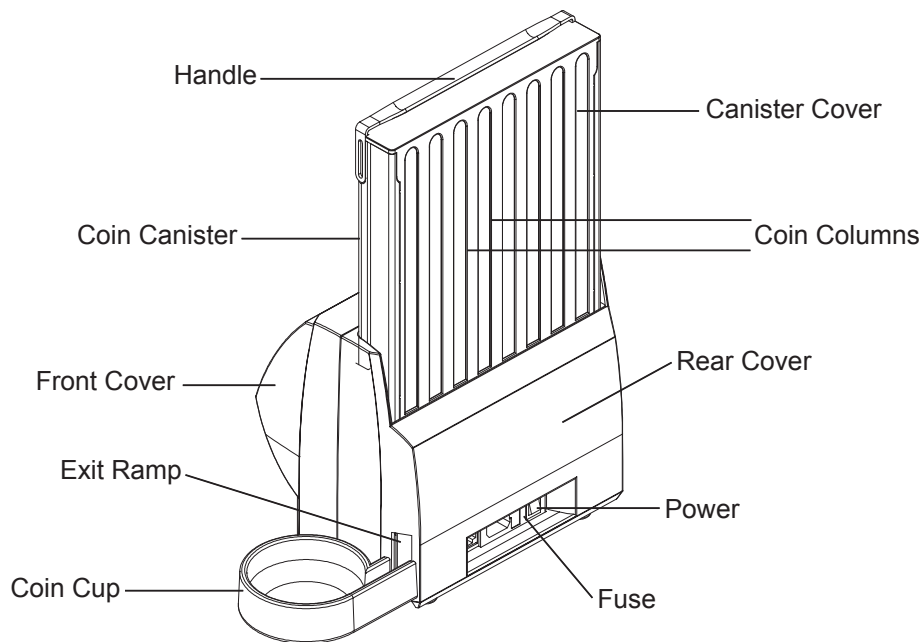

Caution: The coin canister can be very heavy. When you remove the canister or carry it, be careful not to bump or drop it. When you set the coin canister down, make sure that it is on a flat surface or that you place it back into the coin dispenser base.

Loading Coins

You can add individual coins to the canister while it is seated in the base of the coin dispenser or you can fill the canister by performing the following steps or the EZ fill procedure:

1. Remove the canister from the base.
2. Fold the handle back under the canister and set the canister down on a flat surface. The handle will form a shallow angle that is convenient for filling the canister.
3. Remove the plastic cover by compressing the two thumb points on the bottom of the canister while pushing the cover up and off the canister.
4. Hold a manageable number of loose coins between your thumb and first finger; place the stack along the length of the coin column; twist the stack slightly so that the coins drop into position in the coin column. Allow the coins to slide down the column. Repeat this process until the canister is filled to your pre-determined starting level.
5. After loading the coin canister make sure there are no bent coins, pieces of paper, or other foreign objects stuck in the coin columns.
6. Slide the cover back on to the coin canister and re-insert the canister into the coin dispenser.

Coin Alarm

If a column of coins is running out, the low coin alarm will sound. When this happens:

1. Shut off the power with the On/Off switch to silence the alarm.
2. Add coins to the canister, following the steps described in the "Loading Coins" section, or replace with a previously loaded spare canister.
3. Turn the power on.

Maintenance

If the coin canister or base are dirty, wipe them down with a clean, soft cloth that is slightly damp. Do not use abrasive cleaners, solvents, or chemical cleaners on the unit.

The coin dispenser does not require lubrication, so do not apply oil to the unit or use spray lubricant on any of its parts.



Warning: Do not, under any circumstances, remove the front or rear covers from the coin dispenser. High voltages exist inside the chassis that can be fatal. Leave this level of maintenance for the factory, or for a qualified service technician to perform.

Troubleshooting

If you encounter one of the following problems while using the Transact 2+ Coin Dispenser, perform the corrective actions suggested. If this does not fix the problem, contact your service provider or Telequip Corporation.

Coin dispenser will not turn on, alarm does not sound

How to fix the problem:

1. Make sure the Power switch is in the On position.
2. Check to see that the power cable is securely plugged into a live power source. If you are not sure if the power socket is live, plug in another device that you know is working correctly.
3. Inspect the fuse. See page 22 for instructions on removal and replacement.

Dispenser is on, but will not dispense change or has constant alarm

How to fix the problem:

1. Inspect canister for sufficient coin in all columns.
2. Make sure the dispenser is unlocked and that the coin canister is properly seated.
3. Inspect the interface cables for proper orientation and connection to the terminal/POS.
4. Verify the terminal/POS configuration and port settings.

Coin Dispenser is giving out the wrong change

How to fix the problem:

1. The denominations of the coins may be different from what you expect. For example, if the change due is 25 cents, two dimes and a nickel may be dispensed instead of a quarter. This result is not a malfunction.
2. Make sure the coin canister is seated firmly in place.
3. Check for, and remove, any bent coins from the canister.
4. Check for spills and foreign matter in the coin canister.
5. Check for foreign matter in the exit ramp located above the coin cup. Use an unsharpened pencil to dislodge and remove any blockage in the coin ramp.
6. Document the change amount due vs. actual change received. Contact your service provider or Telequip Corp. for technical support.

Coin are jamming and not ejecting properly

How to fix the problem:

1. Make sure the coin canister is seated firmly in place.
2. Check for, and remove, any bent coins from the canister.
3. If the direction of dispense was changed, verify that the coin ramp is in the proper position. See "Changing the Coin Cup" on page 13.
4. Check for spills and foreign matter in the coin canister.
5. Remove the canister from the base and carefully examine it for damage.
6. Replace the coin canister with a backup if available.

EZ Fill Procedure

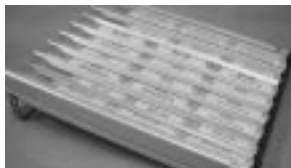

Use canister handle to incline for ease of loading



Snip both ends of coin roll where paper fold meets crimp



Unroll edges and slide roll into canister



Grasp edges and pull paper wrapper up and away



Tel. 603.685.6999
www.telequip.com

© 2003 Telequip Corporation